

## A NOVEL INTEGRATED WIRELESS SENSOR NETWORK ARCHITECTURE FOR DISASTER PREVENTION

<sup>1</sup>Md. Abdullah-al MAMUN, <sup>1</sup>Yuji koi, <sup>1</sup>Naoshi Nakaya, <sup>2</sup>Goutam Chakraborty

<sup>1</sup>Department of Computer and Information Sciences, Graduate School of Engineering,  
Iwate University, Japan, 020-8551,

E-mail: [mamun01117@mn.cis.iwate-u.ac.jp](mailto:mamun01117@mn.cis.iwate-u.ac.jp), [koui/nakaya@cis.iwate-u.ac.jp](mailto:koui/nakaya@cis.iwate-u.ac.jp)

<sup>2</sup>Department of Software and Information Science,

Iwate Prefectural University, Takizawa Mura, Japan 020-0193

E-mail: [goutam@soft.iwate-pu.ac.jp](mailto:goutam@soft.iwate-pu.ac.jp)

*Abstract: There has been growing interest in the application of Wireless Sensor Networks (WSN) in the field of disaster prevention. In such applications, sensor nodes are randomly deployed in an area of interest, a large number of exactly same wireless sensor nodes form a robust mesh network to prevent damages in case of a disaster. In many applications, however, deploying sophisticated sensors on every sensor nodes is unnecessary and very costly. For example, in case of Earthquake one seismographic sensor in an area of a few square kilometers is good enough. Other nodes would then disseminate the sensed information to relevant locations. The main contribution of this work is to propose a WSN architecture and communication protocol for integrated disaster control, when heterogeneous sensor nodes collect relevant information from different locations of the entire WSN and transfer selectively to respective control locations where they could be used for proper disaster prevention. We have actually designed WSN based Disaster Prevention Power Control (DPPC) System which could successfully disseminate alarm signal, and control AC power to facilitate disaster protection. In addition, line interface technique has been developed to interface sensor nodes with physical devices.*

**Keywords: Wireless Sensor Network (WSN), Disaster Prevention Power Control (DPPC), Real-time Emergency Earthquake Reception System (EERS), Power Control Device (PCD), A/D (Analog to Digital) conversion**

## I. INTRODUCTION

Developments of newer sensing devices and the realization of packaging them with a processor and wireless communicating device in tiny size have opened a new paradigm of important applications. Wireless Sensor Networks (WSN) is a fast growing and exciting research area that has attracted considerable research attention in the recent past. In recent years, there have been major advances in various application areas of Wireless Sensor Networks such as disaster relief applications, environment control and biodiversity mapping, intelligent buildings, roads and bridges, machine surveillance and preventive maintenance, medicine and healthcare [1] etc. One of the most mentioned application area of WSN is disaster relief operations.

Sensors are still costly, though processors and wireless communication devices are getting cheap. In this work, we developed an integrated architecture with heterogeneous sensors as information source nodes (e.g., earthquake, temperature, smoke, humidity, illumination and image sensors etc.) and information sink nodes (e.g., Information Center, Power Switching Station, Power Generation Station, Fire protection center etc.) at different installations. A sensor node generates one or more sensed information with different levels of priorities, and to be delivered to destination nodes at diverse locations. We need a suitable communication protocol to disseminate those sensed information to proper destination within tolerable delay. We designed such protocol and implemented on a test bed experiment in our university campus.

Disasters can be categorized depending on their predictability, and delay tolerance for taking preventive measures. For example, earthquake is unpredictable and needs immediate preventive measures to stop chain reactions of disasters that may follow [2]. Similarly, in a

chemical factory accidents like leaking of poisonous gases has to be taken care of immediately. Secondary disasters caused by those calamities can be prevented with assisting controlled features and alerting tasks to secure gases, chemicals and facilities in a safe condition. In both the cases the delay tolerance is of the order of a few seconds. On the other hand, leaking of water pipe, air condition duct etc. could be tolerated for a much longer period before preventive action is to be taken. Thus different disaster signals have different levels of priorities and delay tolerances. According to our survey this aspect is not addressed in any of the previous wireless sensor network to prevent disaster prevention.

From the above discussion, it is clear that we need a wireless network architecture which could guarantee the transmission of important disaster information to the required sink, and within the delay tolerated by the specific type of warning. In this work, we have proposed the architecture of a WSN consisting of a few heterogeneous nodes equipped with different types of special sensors, and a large number of intermediate nodes to form a robust mesh network. The proposed communication protocol ensures guaranteed warning signal transmission from source sensor node to target sink node, where control of disaster prevention takes place. The protocol also ensures the delay requirements by different disaster signal, to propagate from source to destination.

A prototype WSN is realized based on this architecture where Disaster Prevention System is able to prevent the secondary damages of earthquake and fire disaster, by controlling the main AC power supply and initiating warning signals automatically, satisfying required real time constraints. Calamity like earthquake makes rapid damages. Depending on the earthquake intensity, we need to form a robust mesh network immediately to disseminate emergency information within tolerable time delay to target sink nodes. For doing this, in our proposed model we developed an event based embedded software on TinyOS, where strict delay tolerance with different priorities is considered. The main features of the proposed architecture

is to form a scalable, robust, yet relatively simple mesh network by using heterogeneous sensors with less number of costly source and sink sensor nodes at specific locations and hundreds of hopping nodes scattered to facilitate robust communication.

This paper is organized as follows. Section 2 discusses related works and their different approaches. Section 3 explains the disaster prevention WSN requirements and architecture. The prototype system overview is presented in section 4. In section 5, we discuss how we worked out required hardware and its compatible software to implement the prototype system. Emergency Earthquake Reception System (EERS) is discussed in section 6. We also present important features and effectiveness of prototype system in section 6. Finally, section 7 concludes the paper and discusses the future research plan.

## **II. RELATED WORK**

Various researchers have investigated on different methods of disaster relief applications such as disaster prevention information system [3] or emergency disaster bulletin system for human safety. Some of those methods include embedded multimedia communication technology where users can use handheld devices with high mobility via wireless network (3G/GPRS/GSM) to get disaster multimedia stream service. Furthermore, some researches focused on Ubiquitous Structural Monitoring (USM) of buildings for mitigation of seismic hazard [4]. Others proposed to prevent weather/earthquake disaster using real-time weather/earthquake information provided by the meteorological agency.

However, most of those works are related with alerting and monitoring tasks only. Those researches did not focus on the issue of different time delay requirements depending on the kind of disaster and the priority of information generated by the heterogeneous sensors. On the contrary, the motivation of our research is to guarantee the transmission of disaster message from source node to respective sink node (where prevention and control will take place) within

tolerable time delay. This is facilitated using a robust mesh network that could disseminate the sensed data of different levels of priority within tolerable delay.

### III. DISASTER PREVENTION WSN-ITS REQUIREMENTS AND ARCHITECTURE

#### 3.1 Sensor Node

The concept of wireless sensor networks is based on a simple equation:

$$\text{Sensing} + \text{CPU /Memory} + \text{Radio} = \text{Thousands of potential applications}$$

As soon as people understand the capabilities of a wireless sensor network, hundreds of applications spring to mind. However, actually combining sensors, radios, and CPU's into an effective wireless sensor network requires a detailed understanding of both the capabilities and limitations of each of the underlying hardware components, as well as a detailed understanding of networking technologies and distributed systems. Basically, a sensor network is a group of specialized transducers with a communication infrastructure called sensor node intended to monitor and record conditions at diverse locations. The following figure depicts the functional abstraction of a sensor node.

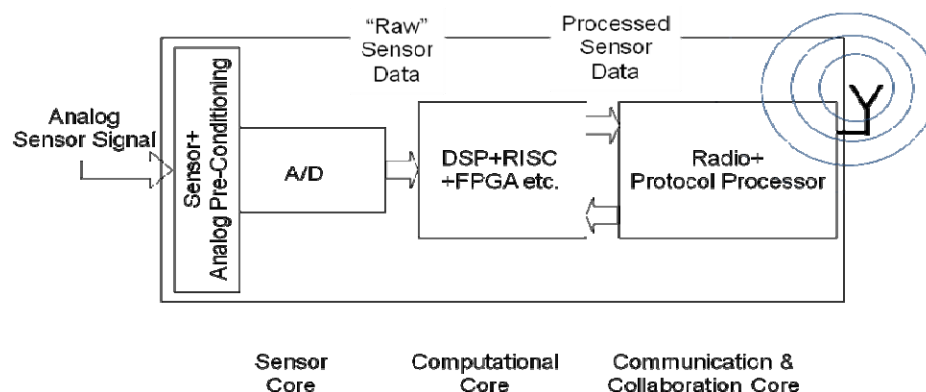

**Fig.1:** Functional abstraction of sensor node

### 3.2 Energy Efficient Communication Protocol for Disaster Prevention

Although many protocols and algorithms have been proposed for traditional wireless sensor networks, they are not well suited for the unique features and application requirements of wireless sensor networks dedicated to disaster prevention [5]. The basic communication protocol requirements in our proposed prototype are outlined below:

- A large number of heterogeneous sensor nodes have been used to build a robust mesh network which should satisfy the scalability problem.
- Low power hopping nodes with limited coverage and communication range but with high density are deployed to ensure robust communication.
- In case of disaster prevention, sensed information with different priorities demands a communication protocol which can disseminate disaster information within required delay tolerance.
- For delay-sensitive applications, various kinds of communication protocols like broadcast, convergecast, and local gossip [6] are used at different stages to avoid data collisions and overhearing problems.
- Common hopping nodes are limited in power, computational capacities, and memory. Therefore, the proposed communication protocol has to be energy efficient.
- Sensor nodes may not have global identification (ID) because of large numbers of sensors.

Large numbers of hopping nodes running energy efficient communication protocol on TinyOS ensure robustness during emergency. In this work, we considered Sensor-MAC (S-MAC) protocol [7] with high duty cycle (low-latency) to avoid data collisions, overhearing, and control packet overhead. Figure 2 shows a chart outlining the power consumption of node subsystem.

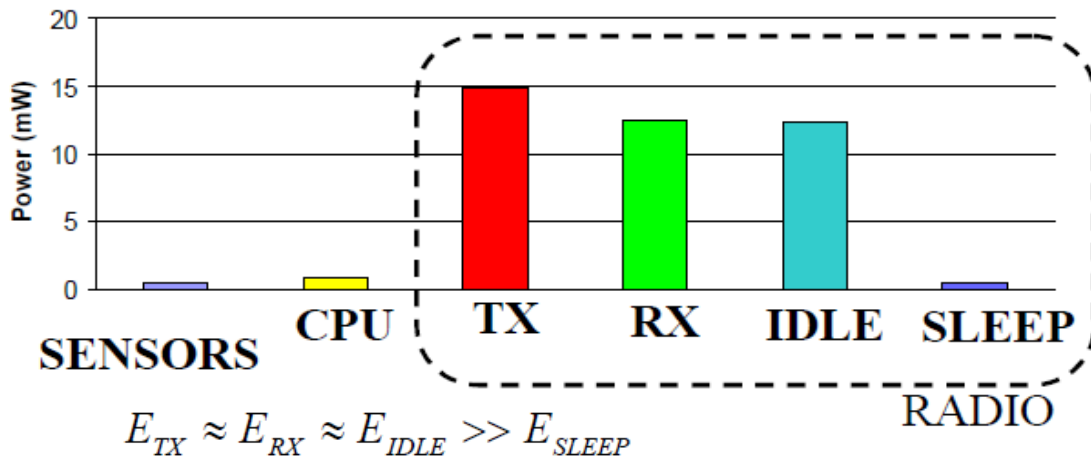

**Fig.2:** Power consumption of node subsystem (From Tsiatis et al. 2002)

The above figure depicts that power consumption in broadcasting mode is almost same as the power consumption in idle mode. One of the major sources of energy waste is *idle listening*, i.e., listening to an idle channel to receive possible traffic. To avoid this problem, in our proposed prototype, we added dynamic duty cycle feature to S-MAC. Here, a hopping sensor node dynamically decides its duty cycle depending on its battery level (whether it's above or below a threshold) and sleep schedule of its neighbor nodes. The sleep schedule is done in such a way that in a neighborhood a small subset of nodes are ensured to be in listen mode.

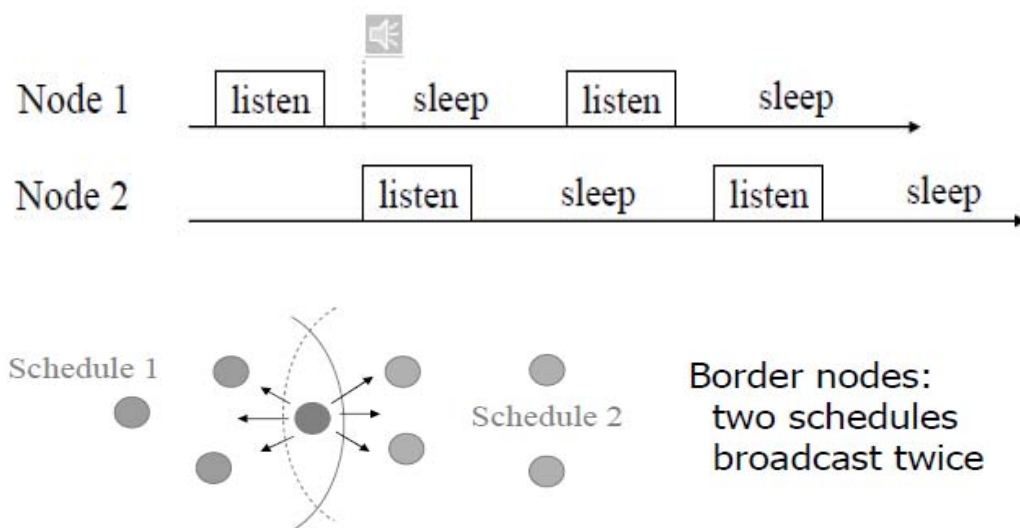

**Fig.3:** Periodic Listen and Sleep with Scheduling

Figure 3 illustrate the periodic listen and sleep schedule where periodic sleep may result in high latency especially for multi-hop routing algorithms, since all immediate nodes have their own sleep schedules. The latency caused by periodic sleeping is called *sleep delay* in [7]. Adaptive listening technique is proposed to improve the sleep delay, and thus the overall latency. The energy loss caused by idle listening is reduced by management of sleep schedules of neighbor nodes. Schedule exchanges are

accomplished by periodical SYNC packet broadcasts to immediate neighbors. The period for each node to send a SYNC packet is called the *synchronization period*. Figure 4 represents a sample *sender-receiver* communication. Collision avoidance is achieved by a carrier sense, which is represented as CS in the figure 2. Furthermore, RTS/CTS packet exchanges are used for unicast type data packets.

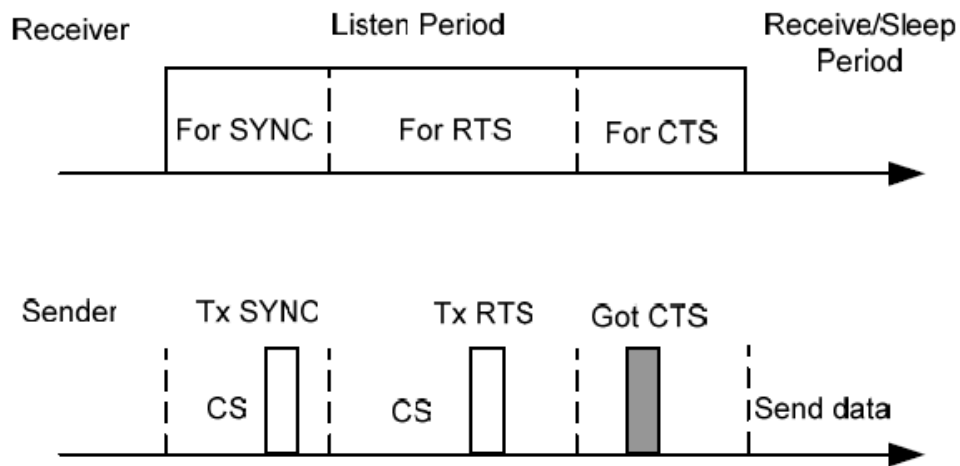

**Fig.4:** S-MAC messaging Scenario [7]

### 3.2.1 Power Management of Hopping Nodes with Dynamic Duty Cycle Feature

One of the important considerations in our proposed WSN architecture for disaster prevention is power consumption [8]. Energy supply for a sensor node is at a premium: batteries have small

capacity, and recharging by energy scavenging is complicated and volatile. Hence, the energy consumption of a common hopping node must be tightly controlled [9].

When a receiver node receives more than one packet at the same time, these packets are called “collided packets” even when they overlap partially. All packets that cause the *collision* have to be discarded and re-transmission of these packets is required. This leads to further energy consumption. Although some packets could be recovered by *capture* effect, a number of requirements have to be fulfilled for its success. The second reason of energy waste is *overhearing*, meaning that a node receives packets that are destined for other nodes. The third energy waste occurs as a result of *control packet overhead*.

Minimal number of control packets should be used for data transmission. One of the major sources of energy waste is *idle listening*, i.e., listening to an idle channel to receive possible traffic. The last reason for energy waste is *overemitting*, which is caused by transmission of a message when the destination node is not ready. Given the facts above, a correctly-designed WSN protocol should prevent these energy wastes.

According to previous section, energy loss for idle listening [Figure 2] demands extra emphasize to design an energy efficient communication protocol. To overcome this problem we used dynamic duty cycle feature in our proposed prototype [10] [11]. We can not compromise the latency for delay-sensitive applications such as disaster prevention where delay tolerance very strict. Within SYNC period, all nodes share their one-hop latency values (time between the reception of a packet into the queue and its transmission). All nodes start with the same duty cycle. When a receiver node notices that average one-hop latency value is high, it decides to shorten its sleep time and announces it within SYNC period. Accordingly, after a sender node receives this sleep period decrement signal, it checks its queue for packets destined to that receiver node. If there is one, it decides to double its duty cycle when its battery level is

above a specified threshold, shown in figure 5.

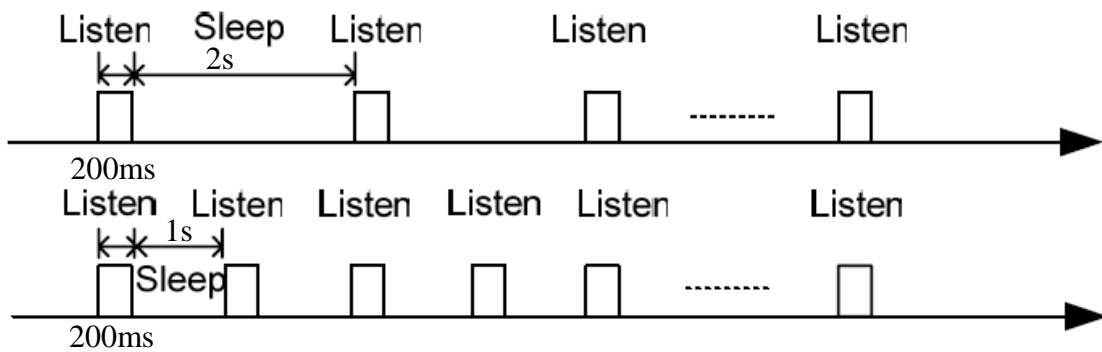

**Fig.5:** Dynamic duty cycle doubling [10]

Figure 5 represents the dynamic duty cycle management of hopping sensor nodes. Here the duty cycle is doubled so that the schedules of the neighbors will not be affected.

Duty Cycle,

$$D = \frac{\tau}{T}$$

Where  $\tau$  is the duration when the node is active and T is the total period.

In this way, the duty cycle is increased by about ~10% which decreases the latency and ensures robustness of communication during emergency. When the residual battery power is reduced, the proposed protocol is able to re-adjust the duty cycle at the cost of increased latency. The energy loss caused by idle listening is reduced by managing sleep schedules of neighbor nodes.

#### IV. Description of the prototype system

Based on the system architecture described in the previous section, we actually implemented a prototype system. The following figure describes the complete control system diagram of DPPC (Disaster Prevention Power Control) where a less number of costly sensor nodes and a

large number of hopping sensor nodes were deployed over a wide area of interest to build a robust mesh network. The network consists of one or more control centers (sink nodes) where the wireless nodes were connected to the physical devices through a wire lined connection. Hundreds of common hopping nodes were scattered across the area of deployment. A unique ID is assigned to each sink node prior to deployment. Basically there are three kinds of nodes in the network: common hopping nodes, gateway (sink) nodes, and Emergency detection nodes. Emergency detection nodes are activated depending on the emergency information, which is provided through a real time emergency earthquake reception system (EQ-Guard), or other disaster sensors

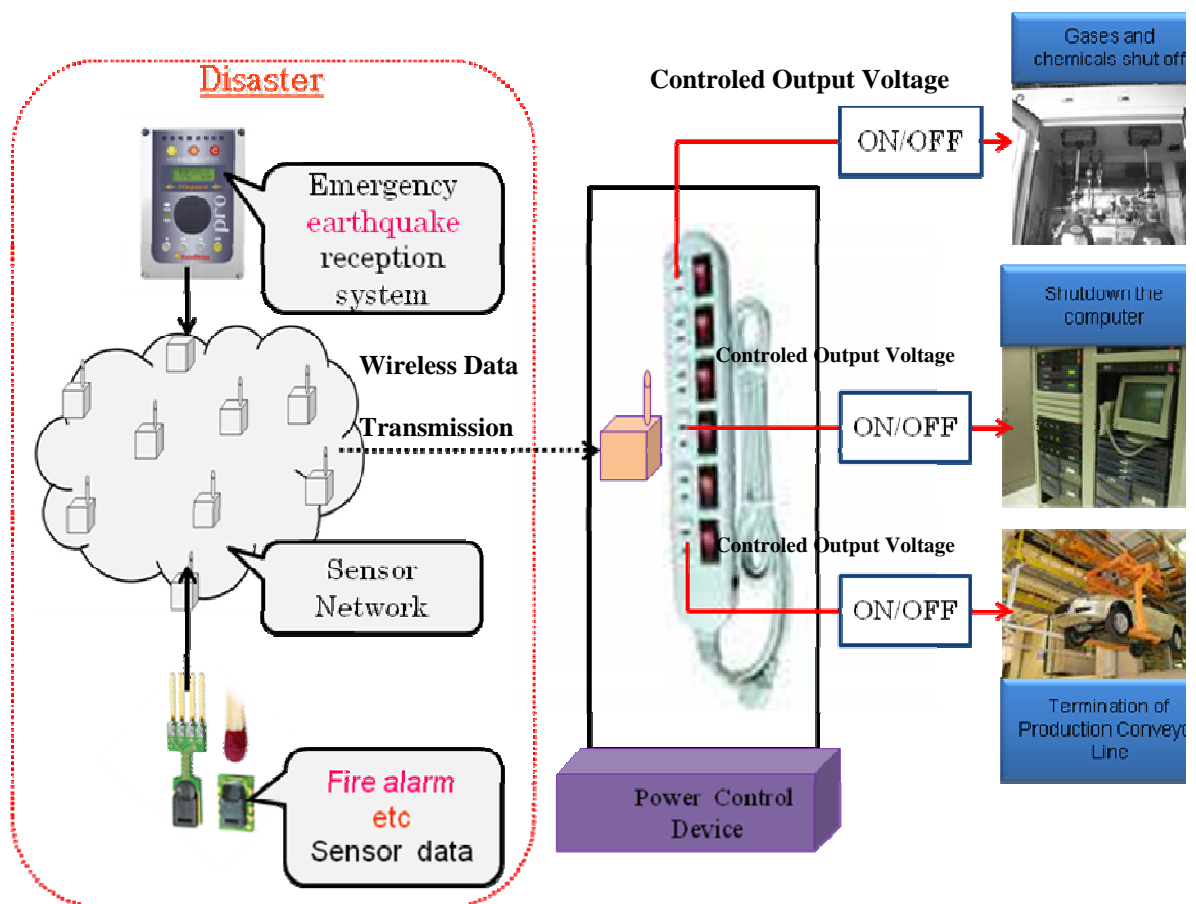

**Fig.6:** Disaster Prevention Control System Diagram

One of the important features of this system is to use only one costly seismographic sensor to ensure safety of a few square kilometers to provides real-time emergency earthquake information to the connected sink nodes. Emergency detection node starts broadcasting earthquake information and forms a robust mesh network at the time of emergency. Figure 6 describes the WSN based disaster prevention control system diagram. Each of these scattered sensor nodes is capable to collect data and to forward the data back to the target sink node connected with the power control device (PCD) and other monitoring system. In this way, the disaster data is delivered to different PCDs and monitoring systems at the remote site through wireless network connections.

According to the disaster information provided through the sensor network, the sink node (target stations) delivered the control signal to Power Control Devices which are connected with main AC power supply. Depending on the sink node's control signal our developed PCD activated and controlled the output voltage and also performed required switching applications to ensure the safety operation for disaster relief. The important features are,

- Shut down the server computer to prevent computer hard disk crash and to protect from severe data loss.
- Shut off gases and chemicals to prevent the secondary disasters.
- Termination of production conveyor line operation to prevent economic damages.
- Ensure human safety by alerting through the networked remote monitoring system.

The following figure 7 shows the network diagram, its status depending on emergency earthquake information system and other sensed alarm data with different priority levels.

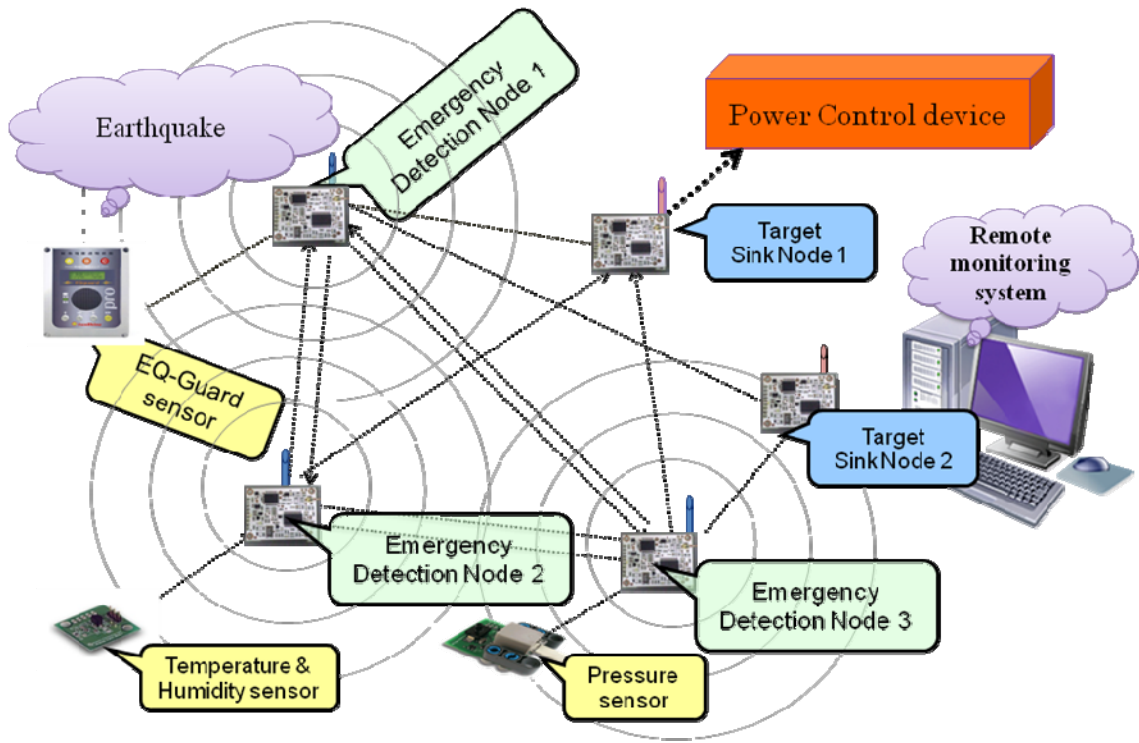

Fig.7: Robust mesh network during disaster

## 4.1 Hardware and Software Implementation

### 4.1.1 Control Center (Sink node) Interface

The network consists of one or more control centers which are sink nodes where sensor nodes are connected to physical control devices through the wired interface connection. The following figure depicts the interfaces technique for two main control centers (sink nodes).

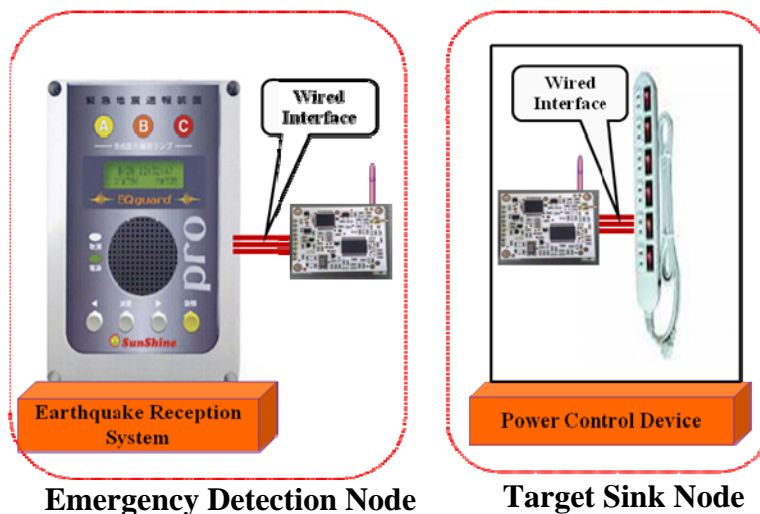
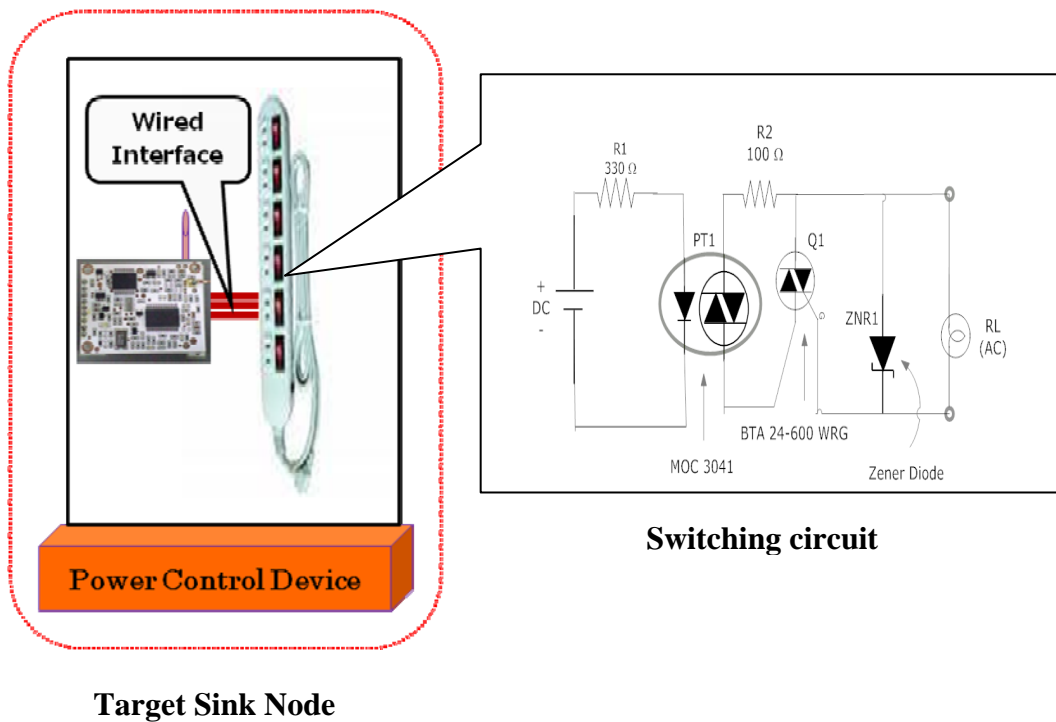

Fig.8: Interfaces between sensor node and physical devices

#### 4.1.2 Switching Technique of Power Control Device

According to the sensed information with different levels of priorities, target sink nodes deliver proper control signals to our developed PCD, and controlled main AC power supply to ensure disaster relief operations. Following is the switching circuit diagram which is used in PCD to control the AC power supply.

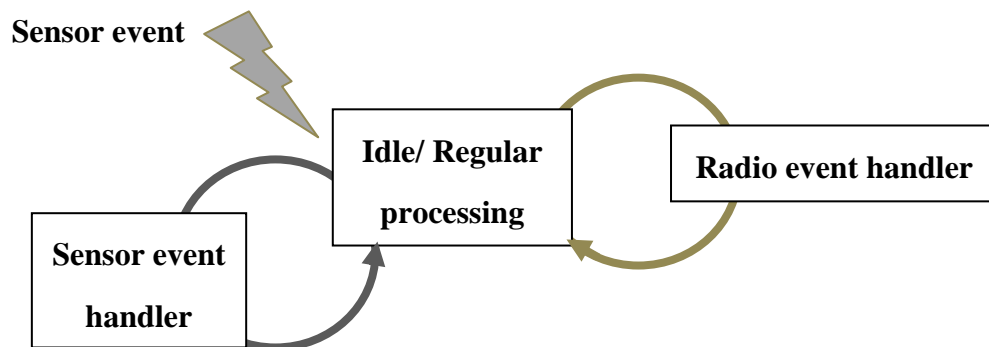

**Fig.9:** Switching Circuit of Power Control device

#### 4.2 Embedded System on TinyOS

In this project, a compatible embedded system software (TinyOS) has been developed in assembly language for gateway (Sink) and hopping sensor nodes. Each sensor node equipped with data processing and communication capabilities. The developed energy efficient execution code supports energy management, for example, in the form of periodic listen and sleep mode [7] with dynamic duty cycle features [10] [11] to ensure the robustness. Also, external components – sensors, the radio modem, or timers – are handled easily and efficiently.

Delay tolerance functionality and prioritizing information generated by sensor nodes are included in the embedded execution code. Here, we used event-based programming model, embrace the reactive nature of WSN node, and integrated it into the design of embedded operating system. The system essentially waits for any event to happen, where an event typically is an emergency data from a sensor, the arrival of a packet, or the expiration of a timer. Such an event is then handled by a short sequence of instructions and stores the necessary information. This **event-based programming** [12] model is sketched in Figure 10.



**Fig. 10:** Event-based programming model

The following simple strategies were followed to make sensor nodes compatible to our application.

➤ **Emergency Detection Node and Hopping Sensor Node**

- ID Settings.
- A/D conversion settings for analog sensor data
- Broadcast sensed information with different level of priority within required delay tolerance

- Sleep mode at normal condition for gateway node
- Event based wake up routine during emergency condition (gateway node)
- Manage periodic listen and sleep schedule for common hopping sensor nodes
- Wake up sensor node (idle listening) according to watchdog timer (WDT) routine

➤ **Target Gateway (Sink) Node**

- Setting of Reception ID
- Wake up sensor node by timer interrupt routine.
- Starts to receive disaster data through timer interrupt routine.
- Serial data transmission to the networked monitoring system.
- D/A conversion and provides analog controlled signal to Power Control Device.
- Standby mode at normal condition

## **V. Overview of Emergency Earthquake Reception System**

In our research project we used emergency earthquake reception system named EQ-Guard based on JAMA (Japan's Meteorological Agency) as a seismographic sensor to the emergency detection (gateway) nodes. JAMA (Japan's Meteorological Agency) anticipated emergency earthquake information to EQ-Guard through internet LAN connection before the tremor begins. The warnings from JAMA are based on the fact that primary waves (first waves of an earthquake) travel faster than the secondary waves that typically do the real damages.

Depending on the JAMA's emergency data the transmission side gateway (source) node starts to broadcast earthquake information through hundreds of common hopping nodes and finally forms a robust mesh network. Thus, the target sink node receives earthquake information and provides control signal to the PCD (Power Control Device) within tolerable delay. The following figure shows the system architecture of real-time earthquake warning system. Here in this figure, meteorological agency delivered their inspected data depending on seismic center latitude, seismic center longitude and also seismic center depth. That information helps our seismographic sensor to detect earthquake intensity and its exact location accurately. Thus our proposed prototype ensured safety operations successfully to prevent secondary earthquake disaster over a robust mesh network within relative delay-sensitivity.

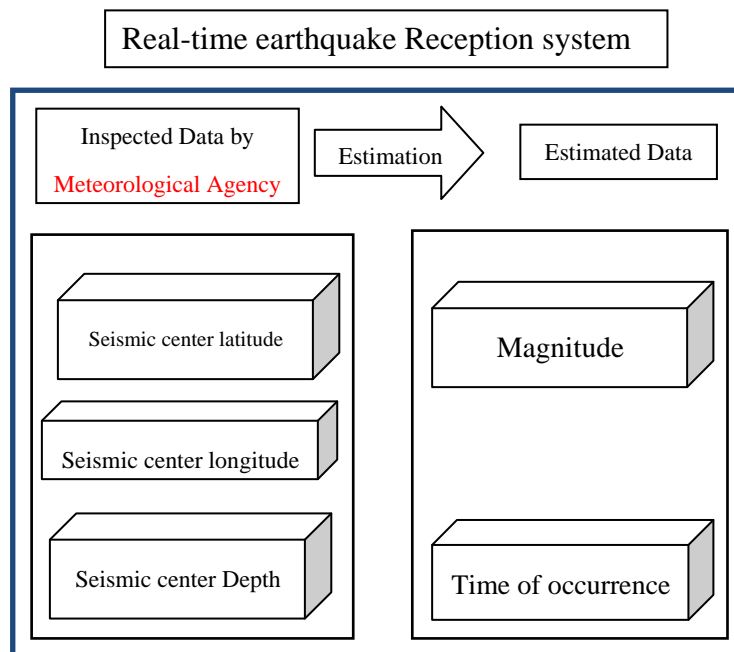

**Fig.11:** Real-time Earthquake warning System Architecture

### **5.1 Important Features and Effectiveness of the Prototype System**

The developed DPPC can be triggered by particular threshold values of sensed data of source nodes to assist the disaster relief operation and warning tasks. In case of earthquake disaster control applications, if the arrival of large tremor is forecasted, even just ten seconds before its arrival, our developed WSN based prototype system would be able to ensure human safety by alerting jobs. It also automatically controls hundreds of switching applications in a manufacturing plant to avoid huge economic damages.

As for the safety of employees in particular, psychological preparation, warn them in advance that a tremor will be occurring, leads to the prevention of unforeseen accidents arising from the panic and also makes it possible to secure their safety.

## **VI. Conclusion and Future Work**

In this paper we introduce a fundamentally different approach that utilizes wireless sensor network (WSN) to improve current practices in various kinds of delay sensitive emergency applications. The primary technical and scientific objectives of the system introduced in this paper are to generate innovative solutions for a number of issues that arise during major natural calamities like earthquake. In this paper we presented the model of our Disaster Prevention Power Control System (DPPC) with its different components including the wireless sensor nodes along with the control centers (sink node). Finally we conducted a test bed experiment in our university campus using a prototype model to verify its effectiveness regarding robustness and resilience.

Future work includes developing a more reliable protocol to guarantee the upper limit of delay for different applications. We will also focus on the development of embedded software on TinyOS for sensor nodes that will increase network life time, and also ensures the robustness. In

addition we will direct our research to work out user friendly interfaces between sensor network and other networks such as, RFID network, cellular network, or the internet.

## References

- [1]. I. Akyldiz, W. Su. Y. Sankar subramaniam, and E. Cayirci, “ *A survey on sensor networks*”, IEEE Communications Magazine, vol.40, no. 8, pp. 102-114, August 2002.
- [2]. K. Wakamatsu<sup>1</sup>, M. Matsuoka<sup>2</sup> and K. Hasegawa<sup>3</sup>, “ *GIS-based nationwide hazard zoning using the Japan Engineering Geomorphologic classification map*”, Proceedings of the 8th U.S. National Conference on Earthquake Engineering April 18-22, 2006, San Francisco, California, USA
- [3]. Che-I Wu<sup>1</sup>, Hsu-Yang Kung<sup>2</sup> , Li-Chia Kuo<sup>2</sup>, Chi-Hua Chen<sup>2</sup>, Kuang-Jung Tasi<sup>3</sup>, *Disaster Prevention Information System based on wireless/mobile communication networks*. Proceedings of the Sixteenth (2007) International Offshore and Polar Engineering Conference Lisbon, Portugal, July 1-6, 2007
- [4]. Kurata, N. Saruwatari, S. Morikawa, H. kobori Res. Complex, Kajima Corp., Tokyo; “ *Ubiquitous Structural Monitoring using Wireless Sensor Networks*” Intelligent Signal Processing and Communications, 2006. ISPACS '06. International Symposium, Dec. 12-15 , 2006.
- [5] Perkins, C. (2000). *Ad Hoc Networks*, Addison-Wesley.
- [6] S.S., Kulkarni, “TDMA services for Sensor Networks”, *Proceedings of 24th International Conference on Distributed Computing Systems Workshops*, Pages:604 – 609, 23-24 March 2004.

- [7] W. Ye, J. Heidemann, D. Estrin, “*Medium Access Control With Coordinated Adaptive Sleeping for Wireless Sensor Networks*”, *IEEE/ACM Transactions on Networking*, Volume: 12, Issue: 3, Pages:493 - 506, June 2004.
- [8] Qin Wang, Mark Hempstead and Woodward Yang, Division of Engineering and Applied Sciences, Harvard University., “*A realistic power consumption model for wireless sensor network devices*” *Sensor and Ad Hoc Communications and Networks*, 2006. SECON apos;06. 2006 3rd Annual IEEE Communications Society
- [9] R. Min, M. Bhardwaj, S.-H. Cho, E. Shih and A. Chandrakasan. Low-Power Wireless Sensor Networks. *In Proceedings of the 14<sup>th</sup> International conference on VLSI Design (VLSID'01)*, Bangalore, India, 2001.
- [10] P. Lin, C. Qiao, and X. Wang, “*Medium access control with a dynamic duty cycle for sensor networks*”, *IEEE Wireless Communications and Networking Conference*, Volume: 3, Pages:1534 - 1539, 21-25 March 2004.
- [11] T.V. Dam and K. Langendoen, “*An Adaptive Energy-Efficient MAC Protocol for Wireless Sensor Networks*”, *The First ACM Conference on Embedded Networked Sensor Systems (Sensys'03)*, Los Angeles, CA, USA, November, 2003.
- [12] J. Hill, R. Szewczyk, A. Woo, S. Hollar, D.E. Culler, and K.S.J. Pister. “*System Architecture Directions for Networked Sensors*”. In *proceedings of the 9<sup>th</sup> International Conference on Architectural Support for Programming Languages and Operating Systems*, pages 93-104, Cambridge, MA, 2000.